



INCORPORATED
WWW.D-2.COM



D-2 Incorporated

OCEAN CT

Environmental Monitoring of
Conductivity + Temperature

HIGH PERFORMANCE / LOW COST

Drawing Number: 315-001R1
Revision Date: 18FEB20



D-2 New OCEAN-CT Sensor:

- A low cost alternative for upper ocean conductivity and temperature measurements.
- The sensor uses a traditional inductive conductivity sensor, with high stability glass tube to improve measurement accuracy.
- Ideal for use of on coastal monitoring platforms.
- Serial outputs of conductivity, temperature and salinity.

Features of the Conductivity Sensor

1. Fully self-contained digital data sensor.
2. Ultra-Low Power processor
3. 2 Hz sampling is continuous.
4. Shallow Ocean / Extended Deployment / Precision Measurement.
5. Configured Communication: RS-232/RS-485
6. Delrin housing; depth up to 50 m.

Features Continued...

7. Calibration to ISO-17025
8. Seacon HUMK Connector w/ 3m long waterproof mating cable

Options:

1A. Data Output Type

- RS-232
- RS-485
- Baud Rate
- Data Rate

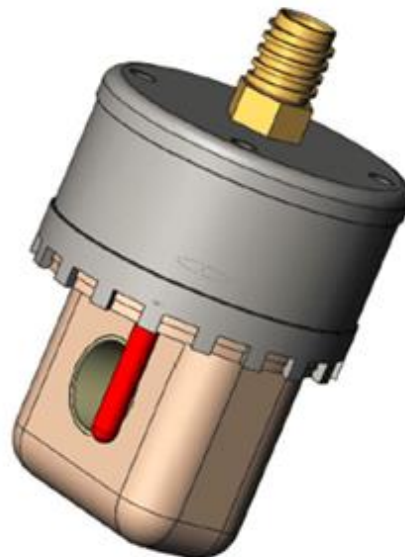
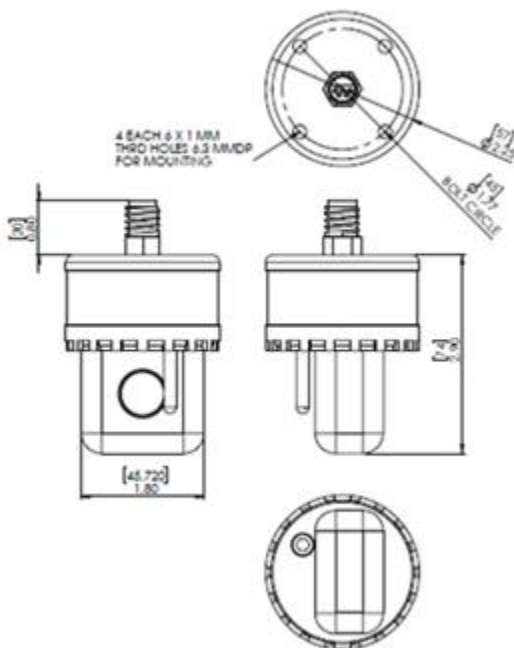

D2 Ocean CT Specifications:

Conductivity Range: 0 to 60 mS/cm

- Accuracy: 0.02 mS/cm
- Resolution: .005 mS/cm
- Sampling Rate: 2 Hz

Temperature Range: -5 to 40 Deg C

- Accuracy: 0.02 Deg C
- Resolution: .005 Deg C
- Sampling Rate: 2 Hz

Performance:

- Stability 0.005 mS/cm per Month
- Resolution 20 Bits
- Sampling Speed Standard 2 Samples/Second
- Supply 5 - 16 VDC
- Power 80 mW @ 5VDC Input
- Communication RS-232/RS-485 Half Duplex
- Baud Rate: User Selectable to 110K Baud
- Data Format ASCII Units mS/cm, C, IPSS
- Data Filter Medium Filter User Defined Sample Space
- Connector SEACON HUMK Series 5 PIN



Connector Pin Out:

- 1 Data Power Ground
- 2 Data+
- 3 Power +
- 4 Data -
- 5 No Connection

Pressure Rating:

- 50 Meters

